

# How to maintain joint integrity when converting from metal to plastic

By Christie Jones, market development manager, SPIROL International Corporation

The weakest sections of many plastic part designs are the joints and assembly points. During screw assembly of mating components, the screw has to be tightened with sufficient torque to produce the recommended axial tension load between the host component and the threads of the screw in order to prevent loosening.

Ref: FFM981603/132

Originally published in Fastener + Fixing Magazine Issue 98, March 2016.

All content © Fastener + Fixing Magazines, 2016.

This technical article is subject to copyright and should only be used as detailed below.

Failure to do so is a breach of our conditions and may violate copyright law.

You may:

- View the content of this technical article for your personal use on any compatible device and store the content on that device for your personal reference.
- Print single copies of the article for your personal reference.
- Share links to this technical article by quoting the title of the article, as well as a full URL of the technical page of our website – [www.fastenerandfixing.com](http://www.fastenerandfixing.com)
- Publish online the title and standfirst (introductory paragraph) of this technical article, followed by a link to the technical page of the website – [www.fastenerandfixing.com](http://www.fastenerandfixing.com)

You may NOT:

- Copy any of this content or republish or redistribute either in part or in full any of this article, for example by pasting into emails or republishing it in any media, including other websites, printed or digital magazines or newsletters.

In case of any doubt or to request permission to publish or reproduce outside of these conditions please contact: [editor@fastenerandfixing.com](mailto:editor@fastenerandfixing.com)

# How to maintain joint integrity when converting from metal to plastic

By Christie Jones, market development manager, SPIROL International Corporation

The weakest sections of many plastic part designs are the joints and assembly points. During screw assembly of mating components, the screw has to be tightened with sufficient torque to produce the recommended axial tension load between the host component and the threads of the screw in order to prevent loosening.

**A** common problem with bolted joints is that plastics are susceptible to creep or stress relaxation. Under loads well below the elastic limit, plastics will lose their ability to maintain a load. When this occurs, the threaded connection becomes loose.

Metal threaded inserts significantly improve joint strength in plastic parts and are not themselves susceptible to creep. The larger body diameter and body design of the insert allow the appropriate installation torque to be applied to the screw. These joints do not become loose over time since the brass provides permanent creep resistance for the entire load path of the thread. Additionally, the inserts enable unlimited assembly/disassembly of the components without compromising the integrity of the threads. Ultimately, it is often the metal insert that allows designers to replace cast or machined metal components with less expensive plastic – without sacrificing performance.

## Insert performance terminology

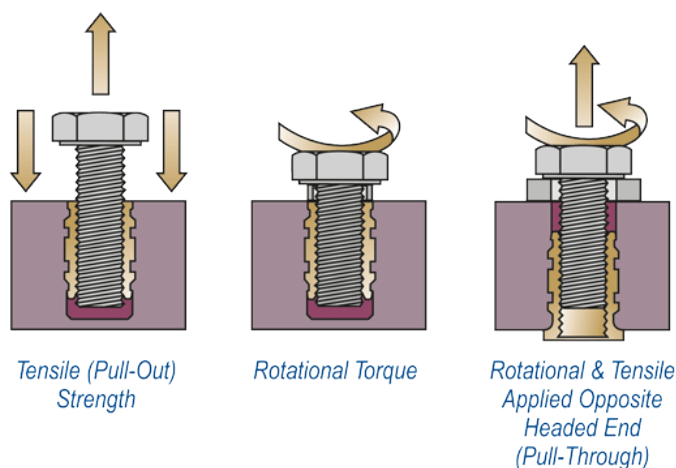

**Figure 1:** Typical performance requirements for inserts involve tensile strength, rotational torque and pull-through strength

Typical performance requirements for assemblies using inserts involve tensile strength, rotational torque, and pull-through strength. Tensile strength, or pull-out, is the axial force required to pull the insert out of the plastic material. Torque is the rotational force required to rotate the insert in the plastic material. Finally, pull-through is a combination of rotational torque and tensile force applied opposite the head of the insert (see Figure 1).

The following factors affect insert performance:

- Insert type, design, and quality of insert features.
- Plastic specifications.
- Design and quality of the plastic components, including hole tolerance consistency.
- The installation process.

Start with the performance requirements of the assembly, and then select the appropriate insert. The objective is to choose an insert with sufficient torque resistance to accommodate the tightening torque necessary to achieve sufficient axial tension load on the threaded joint – to keep it together and prevent loosening – while also achieving pull-out values necessary for the load conditions that the insert will be exposed to while in service. In general, resistance to torque is a function of insert diameter, and resistance to pull-out is a function of insert length.

## How they are installed

There are many different styles of inserts designed to accommodate various performance requirements and installation methods. The installation method must be considered, as this will affect the type of insert that can be used, as well as the overall cost of the assembly. The two primary types of inserts are those that are moulded in and those installed after the moulding process (post-mould).

Moulded-in inserts usually yield the highest performance, yet this form of installation is by far the most expensive. In addition, you run the risk of damaging the mould if the insert is not properly positioned during the moulding process. That can result in tens of thousands of dollars in lost profit.

Inserts installed with heat or ultrasonics after moulding yield good performance at a fraction of the assembled cost of the moulded-in inserts. Post-mould installation is very efficient and eliminates the requirement of properly loading inserts into a mould during the mould cycle. Typically, inserts installed with heat yield the best combination of overall performance and lowest installed cost.

Self-tapping inserts provide the best pull-out resistance for a post-mould insert, yet the assembler has to be very careful about installing the insert so that it is perfectly square to the hole or it will not mate well with the screw.

Expansion inserts are designed for non-critical applications where ease of installation is the primary design criterion, not torque and pull-out resistance. Another low cost option is press-in inserts that are designed to reduce installation cost at a sacrifice of torque and pull-out performance.

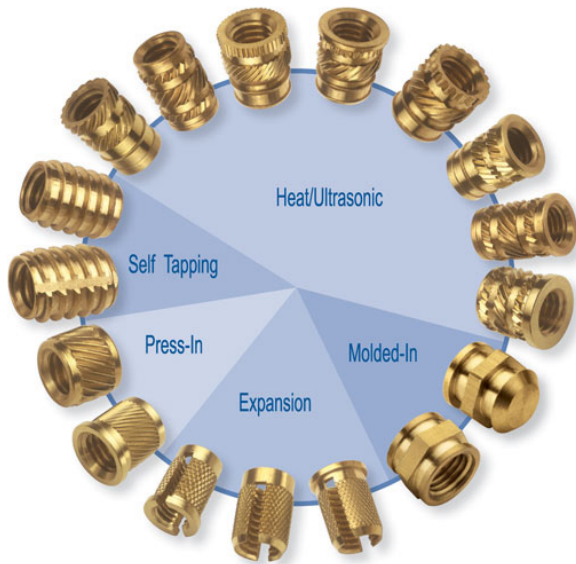

### Hole design guidelines

Correct hole size is critical. Larger holes decrease performance, while smaller holes induce undesirable stresses and potential cracks in the plastic. Undersized holes may also result in flash at the hole edge. The insert manufacturer's recommended hole size for the insert must be adjusted if fillers are used in the plastic. If the filler content is 15% or more, it is suggested to widen the hole by 0.08mm (0.003 inches), and if filler content is 35% or more, the suggested hole diameter increase is 1.5mm (0.006 inches).

Holes for post-mould inserts should always be deeper than the length of the insert. For self-tapping inserts, use a minimum depth of 1.2 times the insert length. For other inserts, the recommended depth is the insert length plus two thread pitches. The assembly screw should never bottom out on the hole, as jack-out would occur.

Moulded holes are preferable to drilled holes because of the strong, denser surface of the moulded hole. Core pins used to mould the holes should be large enough to allow for shrinkage. For straight holes, the taper should not exceed a 1° included angle. Tapered holes should have an 8° included angle (see Figure 2).

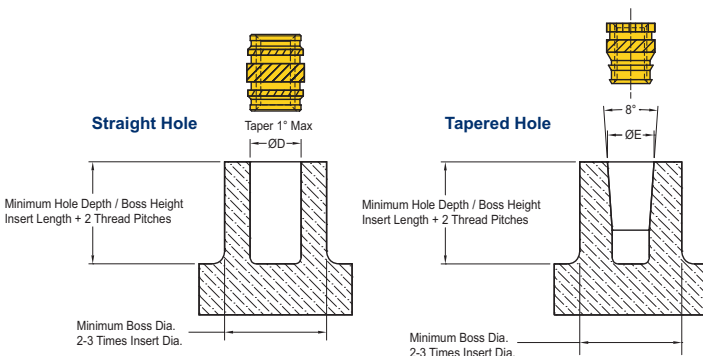

Figure 2: Moulded holes are preferable to drilled holes because of the strong, denser surface of the moulded hole. For straight holes, the taper should not exceed a 1° included angle and tapered holes should have an 8° included angle

Tapered holes reduce installation time and ensure proper alignment of the insert to the hole. Easier release from the core pin is an additional benefit. Only tapered inserts should be used in tapered holes. The disadvantage is that tapered inserts are not symmetrical, and therefore must be oriented prior to installation.

Insert performance is affected by the plastic boss diameter and/or wall thickness. Generally, the optimum wall thickness or boss diameter is two to three times the insert diameter, with the relative multiple decreasing as the insert diameter increases. The plastic wall thickness has to be large enough to avoid bulging during installation and strong enough for the recommended assembly screw installation torque. Poor knit lines in the vicinity of the insert will cause failures and reduced insert performance.

Post-mould inserts that are cold pressed into the hole require larger boss diameters and/or wall thickness to withstand the greater stresses induced during installation. Installing the inserts while the plastic is still warm after moulding generally avoids problems.

### Mating components

The diameter of the clearance hole in the mating component is very important. The insert and not the plastic must carry the load. The hole in the mating component must be larger than the outside diameter of the assembly screw but smaller than the pilot or face diameter of the insert in order to prevent jack-out. If a larger hole in the mating component is required for alignment purposes, a headed insert should be considered. Inserts should be installed flush or no more than 0.13mm (0.005 inches) above the hole.

If the mating component is also plastic, the use of a compression limiter should be considered to maintain the preload of the threaded joint. In order for the compression limiter to work properly, it should abut the insert so that the insert, and not the plastic, carries the load.

Inserts with heads provide a larger bearing surface and a conductive surface if needed. High load applications can benefit from locating the head opposite the load in a pull-through configuration (see Figure 3). Tapered inserts should not be used in pull-through applications or in thin-walled bosses as this will cause cracking of the plastic.

### Pull-through configuration

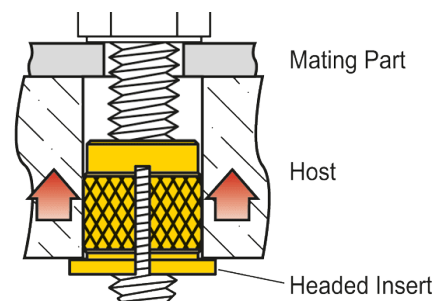

Figure 3: In high load applications, consider locating the head of the insert opposite the load to increase pull-out strength. Tapered inserts should not be used in pull-through applications